

AQC source capture equipment

April 27, 2007 version.  
Leaflet under construction.  
More information to come  
at a later date.

## **MAXIROLL™**

*Portable filtration unit / 600 CFM (1000 M<sup>3</sup>H)*

## **MAXICART™**

*Portable filtration unit / 1500 CFM (2550 M<sup>3</sup>H)*

*For 2 arm configuration*



- *Push-cart type unit*
- *Self cleaning by air pulsation*
- *3 steps filtration system*
- *2 dust collector trays*
- *Tool free maintenance*
- *Swivel casters with foot brakes*



*Superior technology generating substantial operating savings*

# MAXIROLL™ MAXICART™

*High-Productivity Innovative Products*

## MAXIROLL & MAXICART *Compact and portable filtration units*

When welding, grinding or dust source capture is necessary away from a fixed work station, both Maxiroll and Maxicart units are easily moved to the desired location with the help of swivel casters and push handles. Cartridge cleaning is a snap. Simply push the palm button to discharge the compressed air from the integrated tank. Both units have large dust trays at the bottom and emptied when needed. Backward inclined fans deliver great air volume while the foam insulated steel cabin ensures quiet running. Maxair arms are offered with the units or they can also be hard piped to a fume hood or other remote source capture device.

NACD.  
Uniformiser ces  
textes partout  
style et mot-clé  
en gras



## *A Leading-Edge, High-Performance Company*

The AQC Dust Collecting Systems division manufactures a full range of safe, industrial dust collectors, as well as dust and smoke capture equipment at the leading edge of air pollution control technologies based on more than 30 years' experience in the field.

*AQC's strength lies in its innovative products designed and developed to generate substantial savings throughout their entire operating life.*

AQC is renowned for its technological innovation, safe and sophisticated equipment design, as well as its robust and precise product manufacturing. For example, the unique design of the baffles inside AQC dust collectors makes filter cleaning easy. The AQC cartridge holder design provides maximum filter surface and enhanced filter performance. The ultra-smooth concept inside AQC fume arms makes them maintenance-free.

In short, AQC equipment is designed and built to generate substantial operating savings in terms of time, money and energy. This translates to major reductions in operating costs – from 10 to 20% – throughout the equipment's service life. This scale of savings can represent a significant portion of the equipment's total purchase price. Companies looking to maximize their profitability should factor in these savings when purchasing equipment.

*The unique design and manufacturing of AQC equipment generates significant savings for various reasons:*

- Substantial increase in the duration of filters.
- Lower energy consumption during years of use.
- Significantly less maintenance (easy to clean, robust manufacturing, a minimum number of more reliable and durable parts).
- Reduced operating costs (less frequent overhauls, lack of or minimum down time, etc.).
- Lower administrative costs (coordination, follow-ups, supervision) due to much less frequent breakdowns.
- Safe design can prevent serious or even fatal accidents.
- Increased comfort and productivity of personnel.

*Typical acquisition and operating dust collection equipment costs*

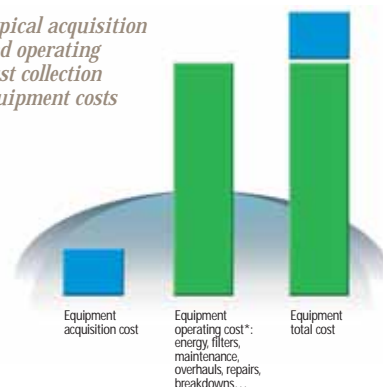

The acquisition cost is just one part of the equation. It's the total cost including the operating cost **\*throughout the life cycle of the equipment** that must be kept low. This is what AQC delivers. The advanced technology, design, robustness, durability and safety of AQC products generate major savings during the equipment's entire life cycle.



## Portable welding and grinding filtration unit

*Portable, powerful, affordable.*

Compare these great features:

- 600 C.F.M. at the hood (1000 m<sup>3</sup>/hour)
- Self-cleaning by air pulsation
- Easy maintenance
- Maxair arm has no internal joints
- 70dbA at 3' (1 meter)
- Backward inclined aluminum impeller

### Outstanding Maxiroll I features



Stainless steel  
Maxiroll picture  
to come

650 C.F.M.  
1100 M<sup>3</sup>/HOUR

**MODELS**

Maxiroll: without Maxair fume arm

Maxiroll: with Maxair fume arm model 1620P

Maxiroll: with Maxair fume arm model 1630P

**SPECIFICATIONS**

1	dt	dfyt	dfs
2			fdtyu
3			
4			
5			
6			
7			
8			
9			
10			
11			

*Electrical note: standard maximum unit is supplied with starter, motor, electrical power cable. Fully assembly...*

Note: it is not recommended to use Maxair 14' (4m) arm unit with Maxiroll unit. Use of such arm make unit tip over.

*Source capture  
has never been so easy...  
and efficient*

**Fan curves**

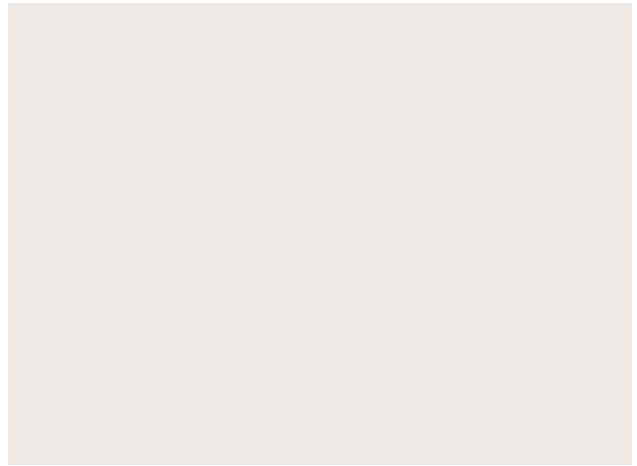

**Motor and air tank specifications**

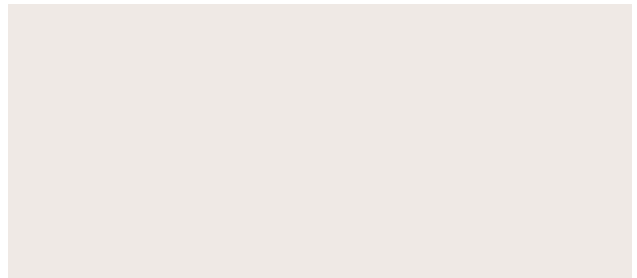

**dessins techniques**

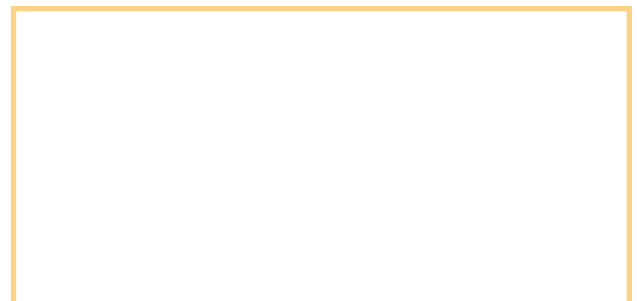

sgsdgdhgdssrh

**MAXICART™** Portable filtration unit

*Higher air volume capability, dual or single fume arm options.*

*Your application is:*

- Portable source capture
- Gouging, plasma cutting, heavy smoke
- Easy/very low cost maintenance of unit
- Two welding or grinding operations side by side
- Dusty air filtration and recirculation possibility
- Minimal or no spare parts required

**Outstanding Maxicart features**



1500 C.F.M.  
2550 M<sup>3</sup>/HOUR

Turn handles on access door to filters and removable dust tray

TEFC motor  
Cabinet grab handle  
Starter with overload protection  
Sealed access door

Access door seal

Spark deterrent aluminum filter  
(2) Polyester main cartridges

Charcoal after filter

Large rear casters

Removable collector tray

Swing arm locking device

8" (200 mm)

Air inlets for Maxair fume arm(s) or hard ducting

6" (160 mm)

**MODELS**

Maxicart: without Maxair fume arm

Maxicart: unit may be equipped with

2 Maxair (6" / 150mm) arms (7-10-14' / 2m-3m-4m) fume arms

1 Maxair (8" / 200mm) arm (7-10-14' / 2m-3m-4m) fume arms

Arms to be ordered separately.

**SPECIFICATIONS**

1	dt	dfyt	dfsu
2			
3			
4			
5			
6			
7			
8			
9			
10			
11			

Electrical note: starter are not wired to motors.

**Fan curves**

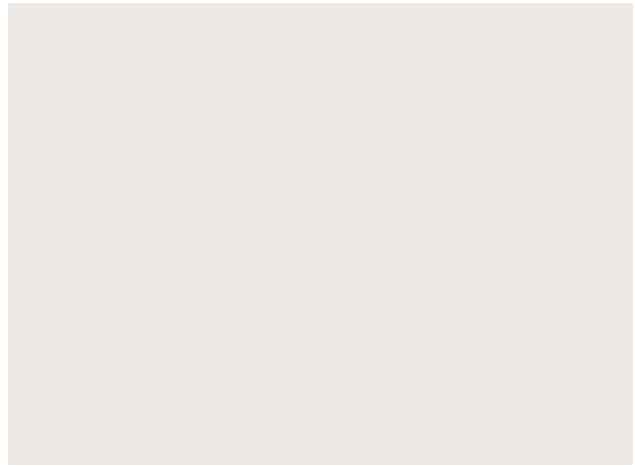

**Motor and air tank specifications**

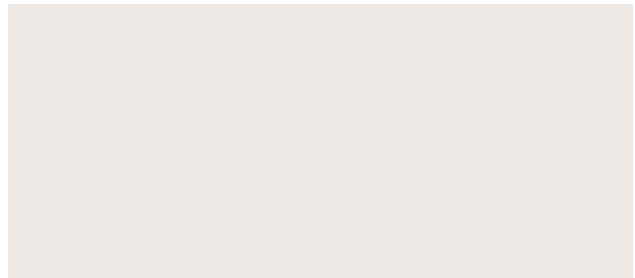

**dessins techniques**

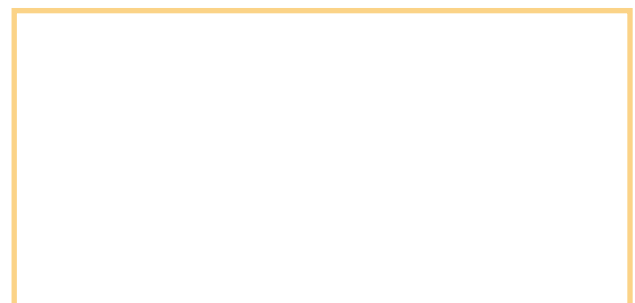

*Source capture  
has never been so easy...  
and efficient*

**MAXIROLL™**

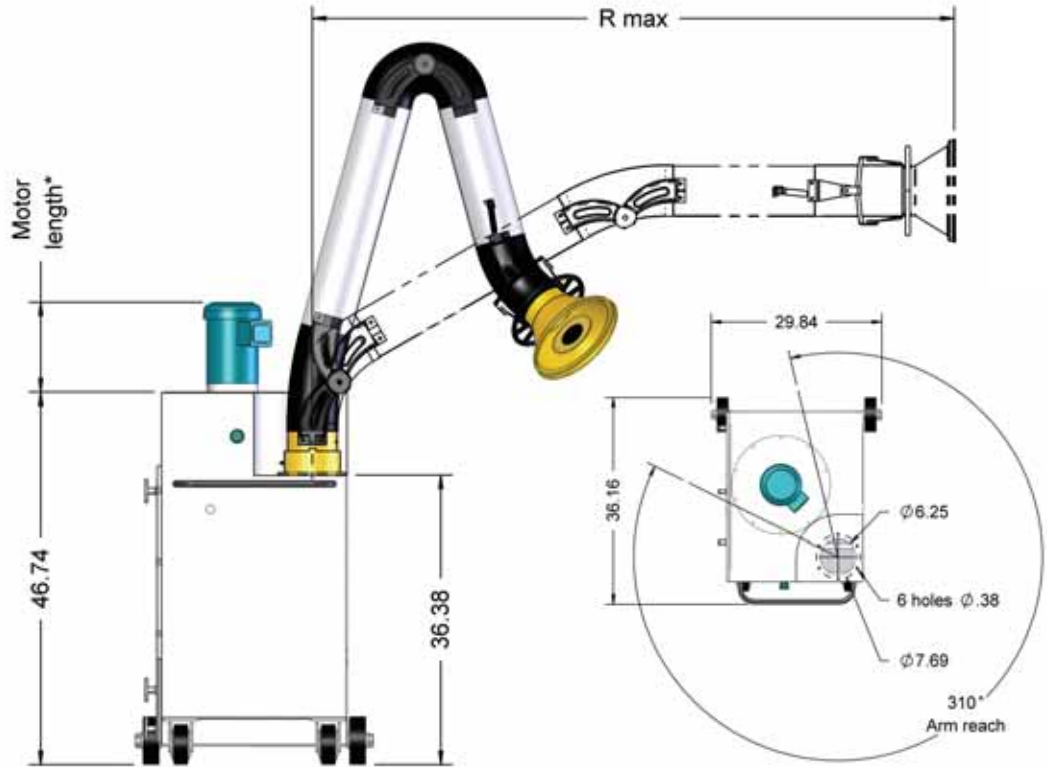
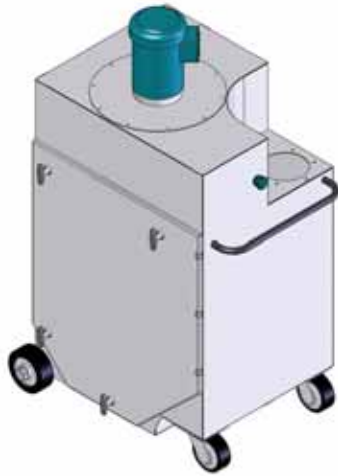

**MAXICART™**

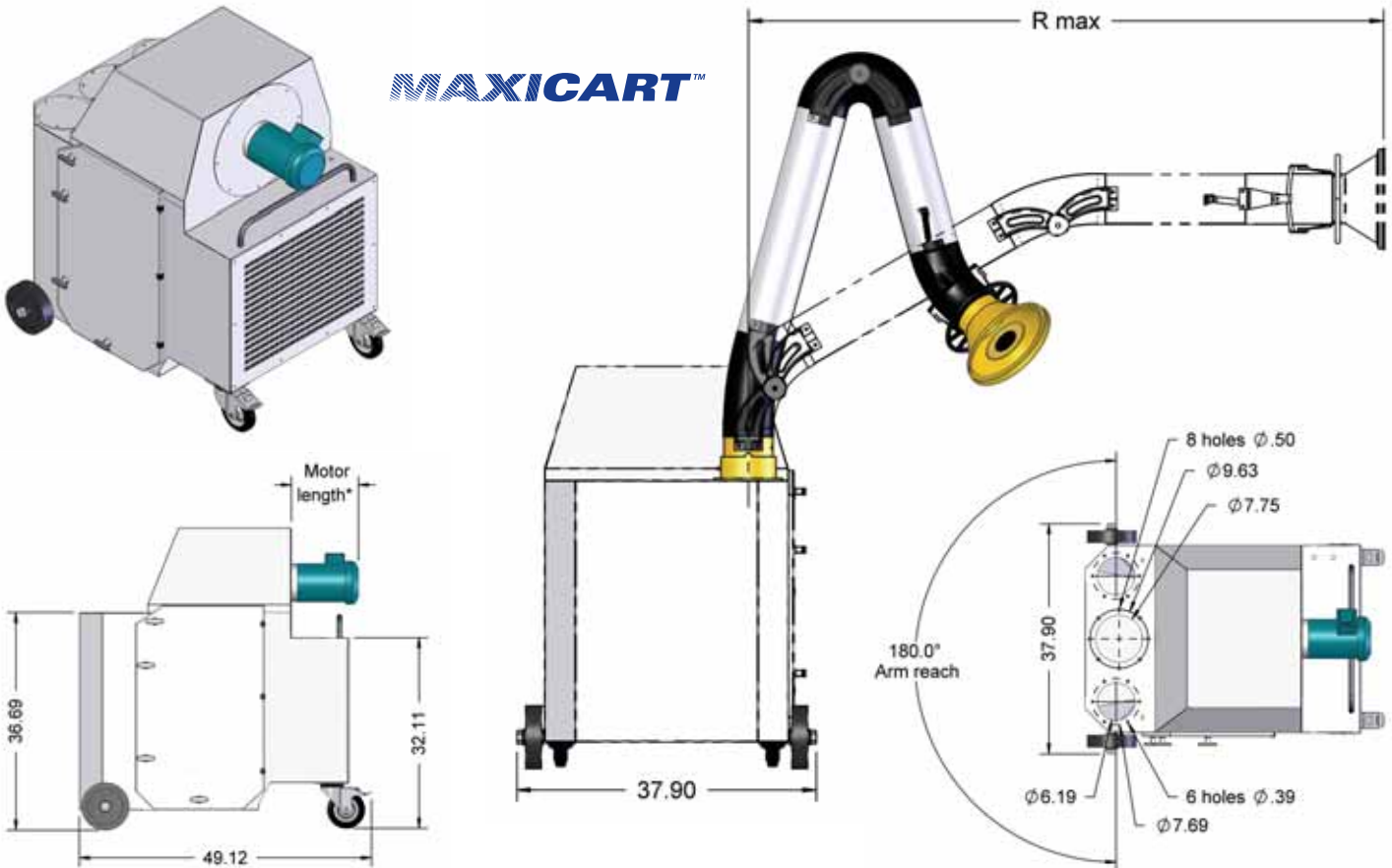
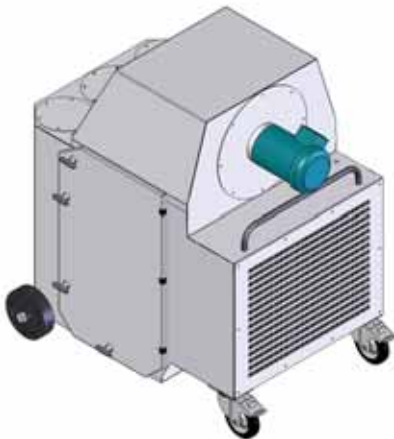

*Safety note: units are not designed to collect possible explosive dusts such as aluminum, magnesium, wood chips or similar). Refer to ASHRAE industrial ventilation handbook for references. If used for such applications, it is highly recommended to empty dust collector drawers in units between applications. DO NOT MIX COLLECTION OF EXPLOSIVE DUSTS IN UNITS.*

## Create your Maxiroll portable filtration unit specification

1. Unit should include:

1 H.P. [0.75 Kw] TEFC 3450 R.P.M. direct drive motor with backward inclined aluminium impeller.

2. Voltage to be: 115/1 /60  230/3 /60

230/1 /60  460/3/60  575/3/60

3. Cabinet should have the following components:

powder coat painted steel housing

sound insulation foam for noise reduction (70 dBa)

swivel casters with foot brakes

sealed access door with twist handles

spark deterrent primary filter, polyester cartridge (99% efficiency), charcoal final filter

cabinet grab handle

starter with overload protection and reset

three (3) gallon reserve air tank for pulse cleaning with palm button operation and air venturi

two (2) removable dust drawers

4. Inlet connection to be:

A) equipped with Maxair fume arm model FA-PPG6-07 (6" X 7')

B) equipped with Maxair fume arm model FA-PPG6-10 (6" X 10')

C) flanged inlet for hard ducting or flexible hose

5. Unit should be equipped with optional:

A) Teflon coated main cartridge

B) automatic pulse cleaning with electronic control panel

C) halogen light kit and hood switch

D) HEPA (99.97%) final filter in exterior housing

E) all stainless steel components for F.D.A. application

F) explosion proof motor and starter

## Create your Maxicart portable filtration unit specification

1. Unit should include:

3 H.P. [2.25 Kw] TEFC 3450 R.P.M. direct drive motor with backward inclined aluminium impeller.

2. Voltage to be: 230/1 /60  230/3 /60

460/3/60  575/3/60

3. Cabinet should have the following components:

powder coat painted steel housing

sound insulation foam for noise reduction (76 dBa)

swivel casters with foot brakes

sealed access door with twist handles

spark deterrent primary filter, polyester cartridge (99% efficiency), charcoal final filter

cabinet grab handle

starter with overload protection and reset

three (3) gallon reserve air tank for pulse cleaning with palm button operation and air venturi

one (1) removable dust drawer

4. Inlet connection to be:

A) equipped with two (2) Maxair fume arms model FA-PPG6-07 (6" X 7')

B) equipped with two (2) Maxair fume arms model FA-PPG6-10 (6" X 10')

C) equipped with one (1) Maxair fume arms model FA-PPG8-10 (8" X 10')

D) flanged inlets for hard ducting or flexible hoses

5. Unit should be equipped with optional:

A) Teflon coated main cartridge

B) automatic pulse cleaning with electronic control panel

C) halogen light kit and hood switch

D) HEPA (99.97%) final filter in exterior housing

E) all stainless steel components for F.D.A. application

F) explosion proof motor and starter



To obtain a free copy of our full-colour corporate brochure, please call : 1-866-629-4356

P.O. Box 72031, Bois-des-Filion, Qc, Canada J6Z 4T7

Tel.: 1-866-629-4356 / Fax: (450) 621-6677

Web site: www.aqc dust.com / e-mail: info@aqcdust.com